

NBM2317 Bus Converter SM-ChiP™ Evaluation Board

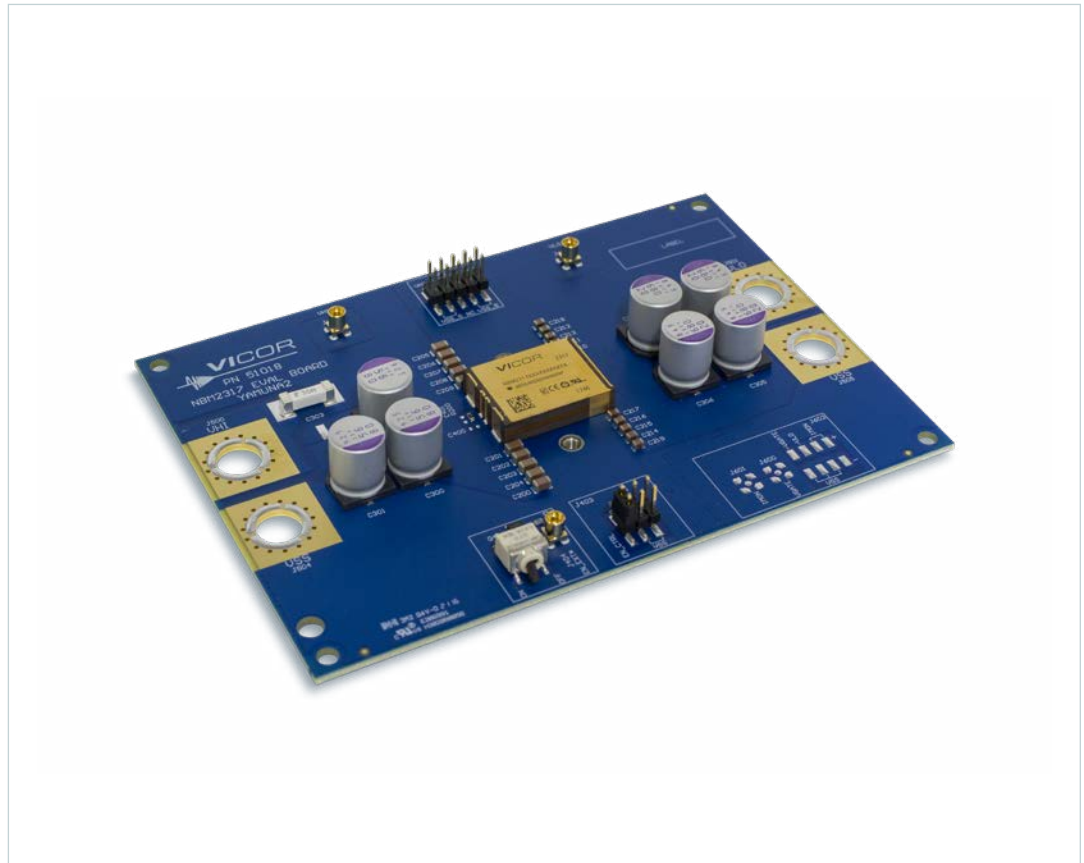

Contents	Page
Introduction	1
Contents	2
Features	2
Board Description	3
General Components	3
Test Point Description	4
Bill of Materials	9
Recommended	
Test Equipment	10
Basic Connections	
and Operation	10
Heat Sink Installation	11



Introduction

The NBM2317 bus converter evaluation board described in this document is designed to be used with the NBM2317S60D1580T0R, SM-ChiP non-isolated, fixed-ratio, bidirectional DC-DC bus converters.

Note: Refer to [UG:701](#) for NBM2317S60E1560T0R evaluation board user guide.

The focus of this document is to assist the user in evaluating of the NBM2317 SM-ChiP™ family.

The NBM™ evaluation board can be configured for various enabling and fault monitoring schemes, as well as to exercise various loading conditions depending on the application requirements. The evaluation board can be used to evaluate NBMs in stand-alone configuration.

It is important to remember that the fast response of NBMs can readily show the limitations of the source, load and associated wiring connected to the evaluation board. Care should be taken to minimize the source impedance as well as high- and low-voltage side interconnect impedances in order to fully realize the NBM performance.

The NBM non-isolated topology allows start up in step-down and step-up directions and provides bidirectional protections. However, if the powertrain is disabled by any fault protection and low side voltage V_{LO} is present, a voltage V_{HI} equal to V_{LO} minus three diode drops will appear on the high-voltage side.



IMPORTANT NOTICE:

Read the precautions below entirely BEFORE using the NBM™ Evaluation Board. Do not operate the evaluation board unless you have the appropriate safety precautions in place on your bench to guarantee safety.

The list below is not comprehensive and is not a substitute for common sense and good practice.

- During operation, the power devices and surrounding structures can be operated safely at high temperatures.
- Remove power and use caution when connecting and disconnecting test probes and interface lines to avoid inadvertent short circuits and contact with hot surfaces.
- When testing electronic products always use approved safety glasses. Follow good laboratory practice and procedures.
- Care should be taken to protect the user from accidental contact when under power.
- Care should be taken to avoid reversing polarities if connecting to the opposite (solder) side of the board.
- The product evaluation boards described in this document are designed for general laboratory evaluation and are not suitable for installation in end-user equipment.
- Refer to the specific NBM module data sheet for electrical, thermal and mechanical product details.

Contents

The evaluation board demo assembly ships with the following contents:

- 1 x NBM evaluation board
- 1 x heat sink and mounting hardware

Features

The NBM evaluation board has the following features:

1. Bidirectional NBM2317 SM-ChiP
2. Input and output bulk capacitance
3. Basic input and output filtering - using low ESR ceramic capacitors
4. Test points for NBM signal terminals (TM/OG and EN)
5. Kelvin voltage test points for all power terminals for input and output voltage measurements

Table 1
Evaluation boards

Part Number	Description
NBM2317E60D1580TOR	NBM2317S60D1580TOR evaluation board

Board Description

This board provides a convenient way to evaluate or demonstrate the performance of the Vicor NBM2317 SM-ChiP™ products. Kelvin connections are provided for accurate voltage measurements on power nodes and signals. The evaluation board also provides lugs for input / output connections and test points for easy connection to standard test equipment.

The following section provides a detailed description of the evaluation board components and test points. The evaluation board is bidirectional, with bulk capacitance included on both the high- and low-voltage sides.

Figure 1
Evaluation board photo



General Components

1. **NBM (PS200):** NBM2317 SM-ChiP non-isolated, fixed-ratio, bidirectional DC-DC converter.
2. **Fuse (F200):** Appropriately rated for the NBM model on the board.
3. **High-voltage-side lugs (J500 and J504):** J500 is labeled as VHI and J504 is labeled as VSS. Use these lugs for making connections to the input source for step-down NBM™ operation or output load for the step-up NBM operation. This board does not contain reverse polarity protection. Check for proper polarity before applying the power. It is important to remember that noise from the source and wiring or interconnect-associated voltage drops will appear at the output of the bus converter multiplied by transformation ratio (K). The K factor is the ratio of the output voltage to the input voltage (V_{OUT} / V_{IN}).
4. **Input and output filtering:** The NBM operates at a switching frequency greater than 1MHz. Low ESR ceramic capacitance are included on the board to minimize the switching voltage ripple. The evaluation board contains ceramic capacitors on the low-voltage and high-voltage sides.
5. **Signal Test points:** The TM/OG and EN signal terminals are accessible through dedicated signal test points header J403. Both signal terminals are referenced to the VSS terminal.
 - **Temperature Monitor (TM):** The NBM TM/OG terminal provides equivalent voltage output for internal controller-junction temperature. It measures 2.1V for a 27°C internal temperature. TM voltage increases / decreases by 7mV/°C.
 - **Output Good (OG):** The NBM TM/OG terminal can be used as a fault flag. It is internally pulled low during a fault condition. The TM/OG terminal can also be used as a ready to process power flag. This terminal is internally pulled high at the end of soft start, indicating when load can be applied.
 - **Enable Control (EN):** Connecting the NBM EN terminal to VSS disables the module. An external logic circuit can be used to turn off the powertrain and disable the module. The EN terminal is internally pulled up to 5V. Note that EN terminal doesn't have current sink capability. Moreover, EN terminal should not be driven high by applying the external voltage source directly to it.
6. **Enable / Disable switch (S400):** Install a jumper between the terminal 1 and 2 (EN and EN_CTRL) of the J403 header to connect the Enable Control circuit to the EN terminal of the NBM. When actuator is in position towards "ON" text on the board, the ENABLE terminal will be open and the NBM will be enabled. When actuator is in position towards "OFF" text on the board, the ENABLE terminal will be connected to VSS and the NBM will be disabled. When switch S400 is ON, an external voltage source can control the ENABLE state though the MMCX connector, J404.

7. **Low-voltage-side lugs (J501 and J505):** J501 is labeled as VLO and J505 is labeled as VSS. Use these lugs for making connection to the output load for the step-down NBM™ operation or to the input source for the step-up NBM operation. This board does not contain reverse polarity protection. Check for proper polarity before applying the power. It is important to remember that noise from the source and wiring or interconnect-associated voltage drops will appear at the output of the bus converter multiplied by transformation ratio (K). The K factor is the ratio of the output voltage to the input voltage (V_{OUT} / V_{IN}).
8. **Power node test points:** Dedicated test points are provided for making accurate measurements of the input and output voltage and voltage ripple. Test points in J400 header are Kelvin connected to input and output voltage signals referenced to the VSS using a Kelvin connection. Also, J402, J401 MMCX connectors are provided to measure the VHI and VLO voltage and voltage ripple.
9. **Heat sink mounting:** J502 and J503 are the heat sink mounting holes with pre-installed surface-mount nuts. Use these holes for mounting the heat sink assembly provided in the evaluation board box. The heat sink kit is Vicor part number MB-EVAL-NBM2317-1X, see Heat Sink Installation section.
10. **Input and output bulk capacitance:** The board contains rated C_{HI-EXT} and C_{LO-EXT} bulk capacitance.

Test Point Description

All test nodes are labeled and include a test point for attaching probes, clips or hooks.

Table 2
Test point descriptions

Name	Description
VHI_S, VSS_S	High-voltage-side test point. Kelvin connections provided for the NBM high-voltage side power terminals.
EN, VSS	EN terminal relative to VSS terminal. Kelvin connection provided to the NBM EN signal terminal.
TM/OG, VSS	TM/OG signal relative to VSS terminal. Kelvin connection provided to the NBM TM/OG signal terminal.
VLO_S, VSS_S	Low-voltage-side test point. Kelvin connections provided for the NBM low-voltage side power terminals.

Please note: The VSS is a common-power / signal-ground reference for the high-voltage-side and low-voltage-side power and signal terminals of the NBM.

Figure 2a
PCB#51018 evaluation board
photo, top side



Figure 2b
PCB#51018 evaluation board
photo, bottom side

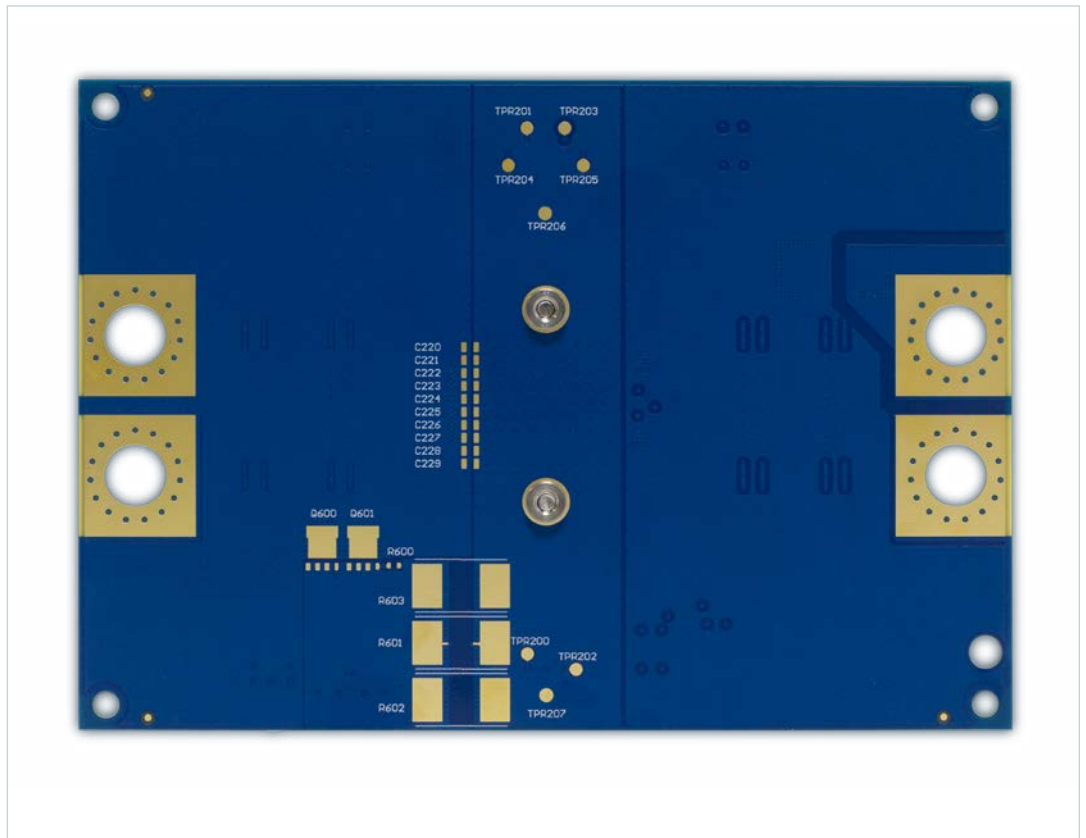

Figure 3b
PCB#51018 evaluation
board schematic, cont.

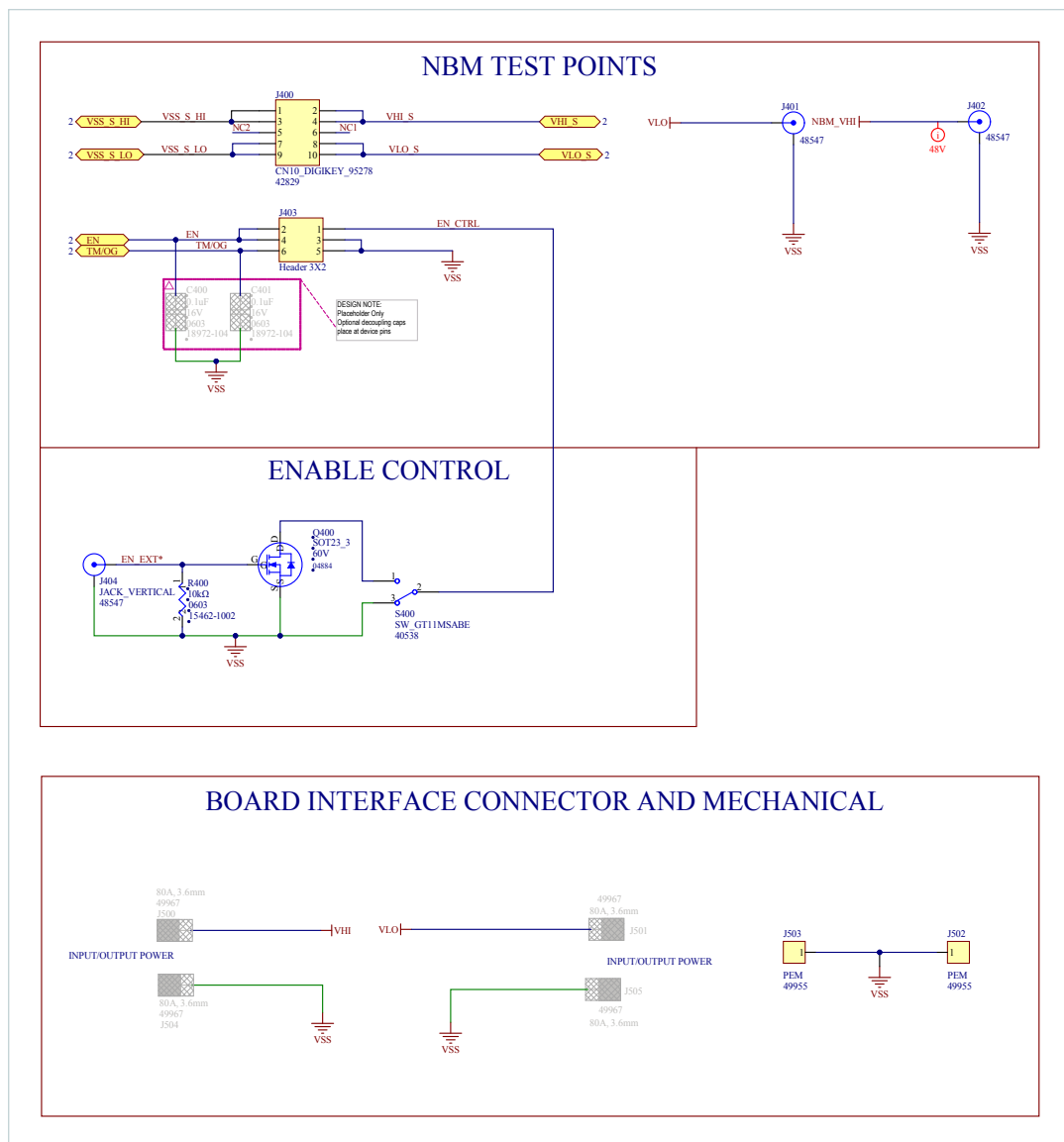

Figure 4a
PCB#51018 evaluation board
assembly drawing, top side

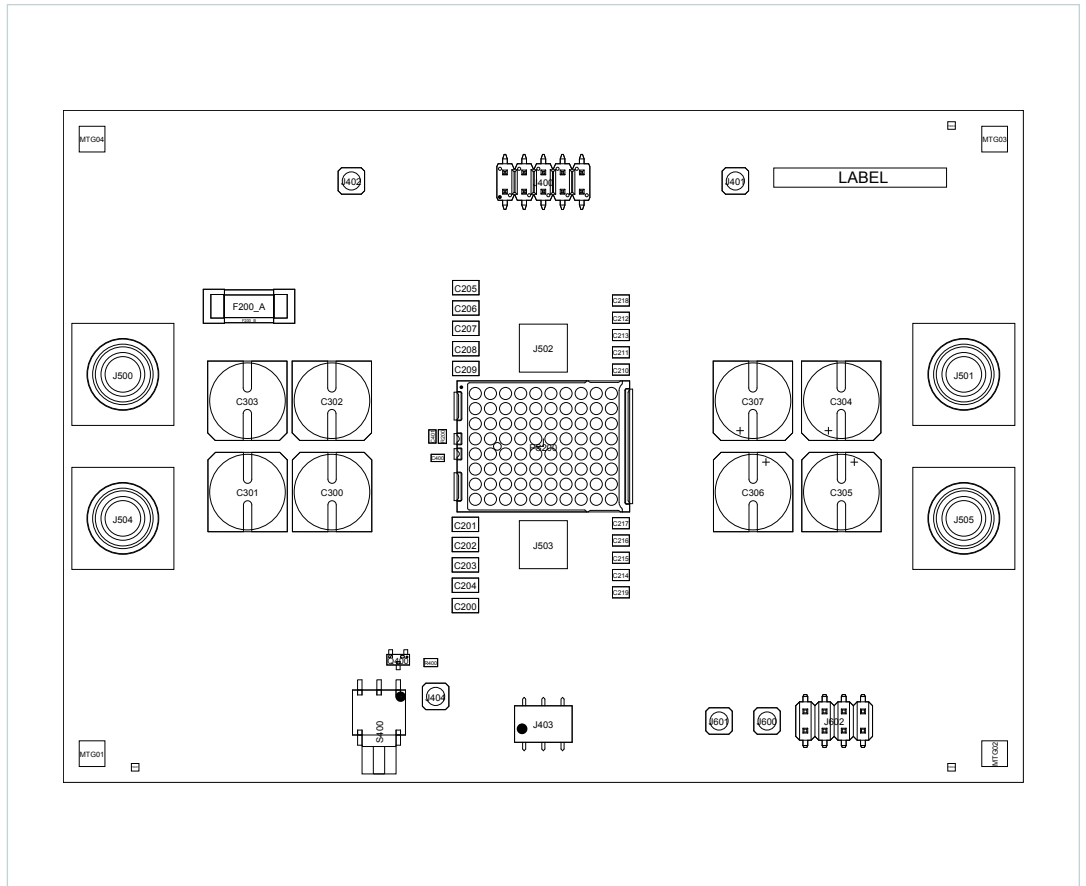
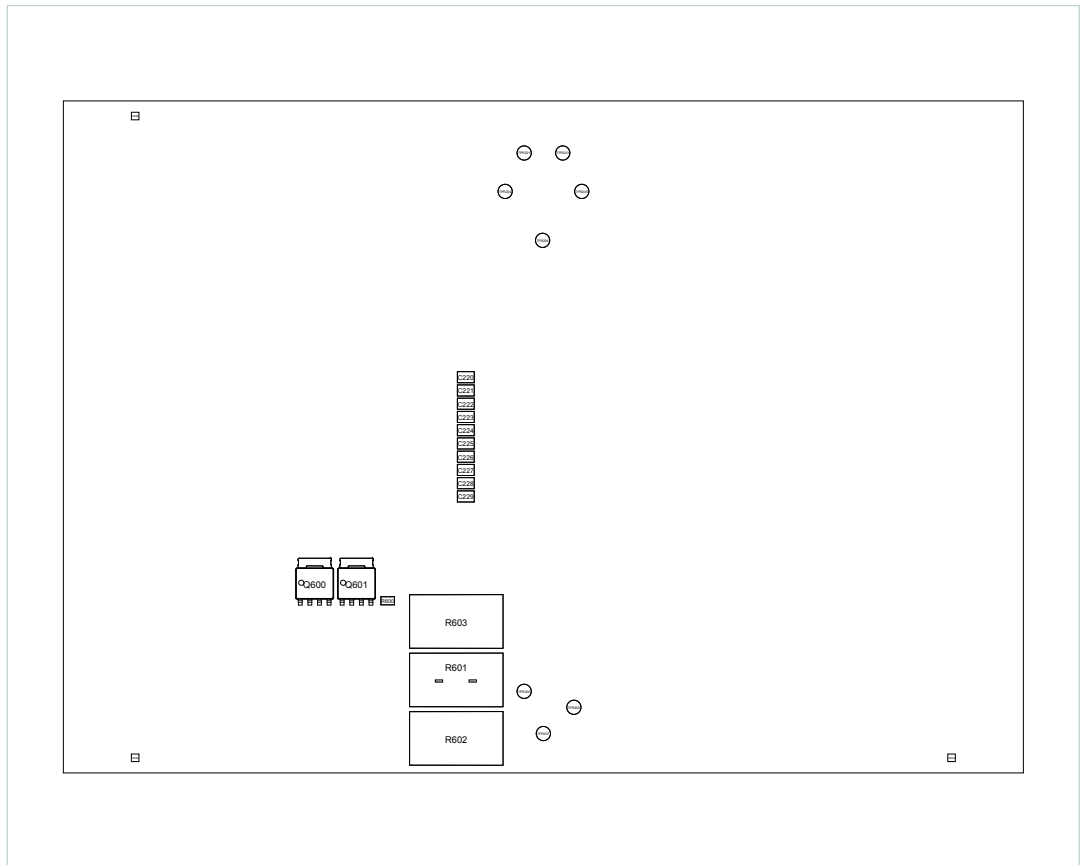

Figure 4b
PCB#51018 evaluation board
assembly drawing, bottom side



Bill of Materials

The following table describes the design-specific components of the NBM™ evaluation boards.

Table 3
NBM evaluation
board components

Reference Designator	Description	Manufacturer	Manufacturer Part Number	Notes
C200, C201, C202, C203, C204, C205, C206, C207, C208, C209	CAP X7S 2.2μF 10% 100V 1206	TDK	C3216X7S2A225K160AB	Low-ESR ceramic capacitors, High-side
C210, C211, C212, C213, C214, C215, C216, C217, C218, C219	CAP X7S 10μF 10% 25V 0805	Murata	GRM21BC71E106KE11L	Low-ESR ceramic capacitors, Low-side
C220, C221, C222, C223, C224, C225, C226, C227, C228, C229	Not Applied			
C300, C301, C302	CAP ALEL POLY 56μF 20% 80V 10x12.7	Panasonic	80SXV56M	
C303	Not Applied			
C304, C305, C306, C307	CAP ALEL POLY 680μF 20% 20V 10x12.7	Panasonic	20SVPK680M	
F200_A	Fuse 30A 125VAC FAST 12.5x4.5 SMD	Littelfuse	0456030.ER	High-side input fuse
PS200	Bidirectional NBM2317 SM-ChiP	Vicor	NBM2317S60D1580TOR	

Recommended Test Equipment

The following is a list of recommended test equipment:

1. Safety glasses
2. DC power supply: Refer to the specific NBM™ model data sheet to ensure the supply has sufficient power and current capability.
3. Electronic load: Refer to the specific NBM model data sheet to ensure the load has sufficient power handling and current capability for testing
4. Cooling fan
5. Digital multi-meters (DMMs)
6. Oscilloscope and probes
7. Interconnect wires, cables and fastening hardware

Basic Connections and Operation

- Confirm bench equipment is powered off.
- Connect the input DC power supply positive lead to the positive input lug of the evaluation board, connect the input power supply negative lead to the VSS input lug of the evaluation board. Please note that VHI is the positive input lug for step-down NBM operation and VLO is the positive input lug for step-up NBM operation. Given the wide bandwidth of the module, the source response is generally the limiting factor in the overall system response. Anomalies in the response of the power source will appear at the output of the module multiplied by its K factor. To take full advantage of the NBM's dynamic response, the impedance presented to its input terminals must be low from DC to approximately 5MHz. Use of a twisted pair of a suitable wire gauge is recommended to provide a low inductance interconnection to the power source. The connection of the NBM evaluation board to its power source should be implemented with minimal distribution inductance. If the interconnect inductance exceeds 50nH, additional capacitance should be placed at the source connection to the NBM evaluation board.
- Connect the positive output lug of the evaluation board to the electronic-load positive input, connect the VSS output lug of the evaluation board to the electronic-load negative input. Please note that VLO is the positive output lug for step-down NBM operation and VHI is the positive output lug for step-up NBM operation.
- Verify proper polarity of the connections.
- Verify all electrical termination fasteners are securely tightened to ensure a proper, low-impedance connection is made between the NBM evaluation board and the external power source and load.
- Direct airflow from the cooling fan across the NBM.
- Have the latest NBM data sheet on hand for reference.

Enable Options:

1. Apply input voltage to the NBM high-voltage side for step-down operation or low-voltage side for step-up operation. Input voltage must be greater than the undervoltage lockout and within the NBM start-up input voltage range.
2. External EN Control using available EN switch or by an external signal EN_EXT* using the MMCX connector, J404.

The load turn on should be delayed until the TM/OG flag is high. Load should not be present at the start up of the NBM evaluation board to allow the completion of NBM soft-start ramp and TM/OG flag is set high.

Power Down:

For quick discharge of bulk capacitance following removal of input power, an external bleeding resistor (1kΩ) can be used from both VHI to VSS and VLO to VSS.

Heat Sink Installation

This section provides instructions on how to install the heat sink onto the evaluation board.

Figure 5
Evaluation board
fully assembled

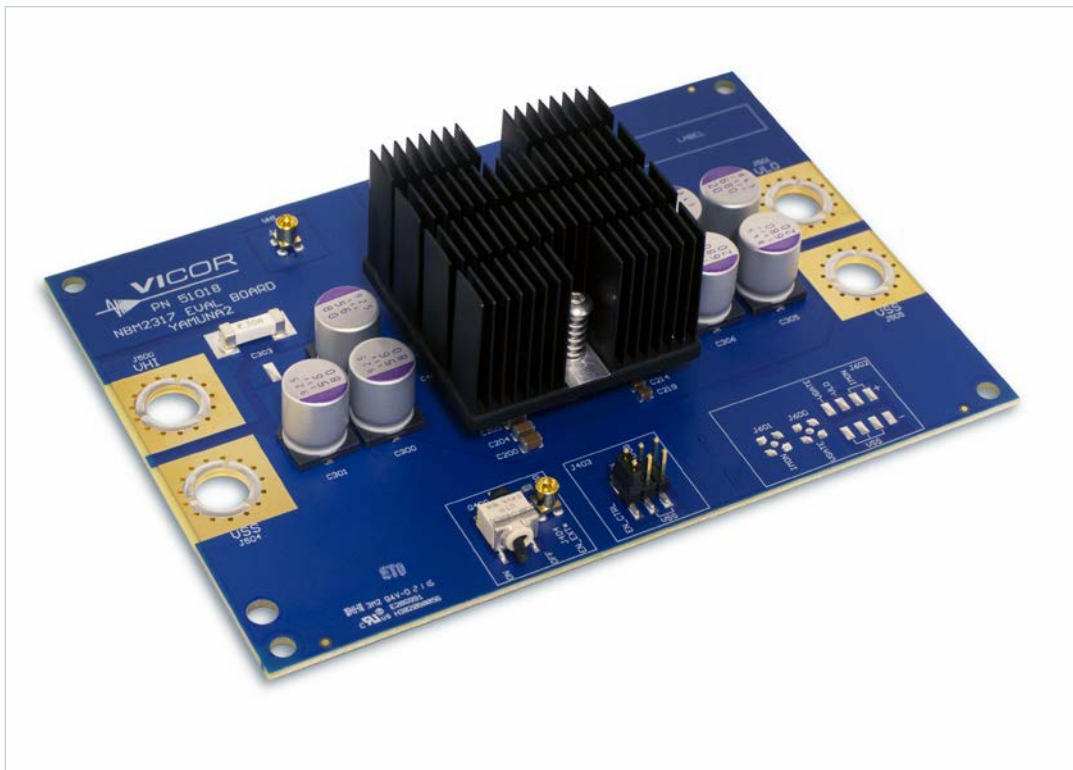

Please note that the heat sink assembly should be done after the completion of the SM-ChiP™ NBM2317 assembly onto an evaluation board or a customer application board.

The evaluation board comes with heat sink mounting holes and pre-installed PEM nuts, which makes the heat sink installation easy.

Utilize the hardware components provided in the heat sink assembly kit, Vicor part number MB-EVAL-NBM2317-1X.

Table 4
Vicor p/n MB-EVAL-NBM2317-
1X component list

Item Reference	Name	Description	Part Number Vicor / MFR	QTY
A	Screw	M3 x 0.50mm thread, 22mm long, button head hex drive, passivated 18-8 stainless steel; McMaster-Carr	50326-22 / 92095A473	2
B	Spring	Standard compression series, passivated stainless steel; Lee Spring	51052 / LC 026BB 035	2
C	Heat Sink	HS 40 x 40 x 25 26CTC LONGITUDINAL MNT HOLE	51455	1
D	Thermal Interface Material (TIM)	SILTEL TIM PAD 25 x 20 x 0.5 THK; TIMTEL	50810 / SG-TC6.0	1

Figure 6 depicts the exploded view of the heat sink and hardware components along with the product evaluation board.

Step 1: Place the TIM on the top surface of the SM-ChiP™ NBM2317.

- Remove the thin protective plastic sheets from both sides of the TIM before installing TIM on the top surface of the SM-ChiP.
- Cover the entire top surface of the SM-ChiP with the TIM to avoid short circuit of the power/signal castellations of the NBM with the heat sink. TIM provides electrical isolation between the NBM surface and the heat sink surface.

Step 2: Place the heat sink on top of the TIM material.

- Heat sink is machined with the mounting holes that match with the mounting holes on the evaluation board. Align the mounting holes on the heat sink with the mounting holes on the evaluation board.

Step 3: Place a set of screw and a spring in each mounting hole as shown in the above figure.

Step 4: Fasten the screws.

- Apply maximum of 20psi z-axis pressure.
- Fasten one screw at a time up to two turns to apply equal pressure on the surface of the SM-ChiP, alternating sides and up to the maximum of 8 – 11 turns. Springs provide 10 – 12.8psi for 8 – 11 turns, respectively.

Figure 6
Vicor p/n MB-EVAL-NBM2317-
1X exploded view

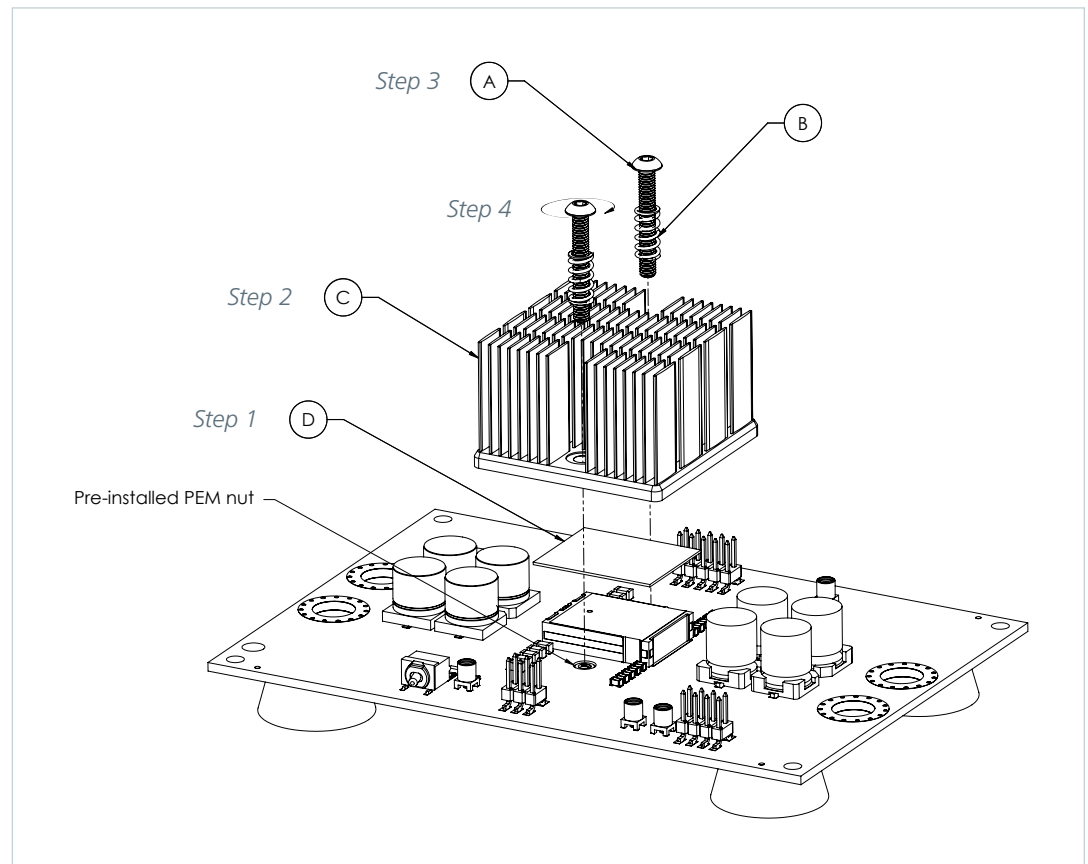

Revision History

Revision	Date	Description	Page Number(s)
1.0	10/26/21	Initial release	n/a
1.1	02/12/24	Removed NBM2317S60D1565TOR from document	2, 10, 12
1.2	06/07/24	Revised input and output filtering, typo corrections Updated heat sink assembly kit information	3 4, 11, 12
1.3	07/16/24	Revised schematic	7
1.4	05/27/25	Corrected terminal number assignments in schematic	6

Limitation of Warranties

Information in this document is believed to be accurate and reliable. HOWEVER, THIS INFORMATION IS PROVIDED "AS IS" AND WITHOUT ANY WARRANTIES, EXPRESSED OR IMPLIED, AS TO THE ACCURACY OR COMPLETENESS OF SUCH INFORMATION. VICOR SHALL HAVE NO LIABILITY FOR THE CONSEQUENCES OF USE OF SUCH INFORMATION. IN NO EVENT SHALL VICOR BE LIABLE FOR ANY INDIRECT, INCIDENTAL, PUNITIVE, SPECIAL OR CONSEQUENTIAL DAMAGES (INCLUDING, WITHOUT LIMITATION, LOST PROFITS OR SAVINGS, BUSINESS INTERRUPTION, COSTS RELATED TO THE REMOVAL OR REPLACEMENT OF ANY PRODUCTS OR REWORK CHARGES).

Vicor reserves the right to make changes to information published in this document, at any time and without notice. You should verify that this document and information is current. This document supersedes and replaces all prior versions of this publication.

All guidance and content herein are for illustrative purposes only. Vicor makes no representation or warranty that the products and/or services described herein will be suitable for the specified use without further testing or modification. You are responsible for the design and operation of your applications and products using Vicor products, and Vicor accepts no liability for any assistance with applications or customer product design. It is your sole responsibility to determine whether the Vicor product is suitable and fit for your applications and products, and to implement adequate design, testing and operating safeguards for your planned application(s) and use(s).

VICOR PRODUCTS ARE NOT DESIGNED, AUTHORIZED OR WARRANTED FOR USE IN LIFE SUPPORT, LIFE-CRITICAL OR SAFETY-CRITICAL SYSTEMS OR EQUIPMENT. VICOR PRODUCTS ARE NOT CERTIFIED TO MEET ISO 13485 FOR USE IN MEDICAL EQUIPMENT NOR ISO/TS16949 FOR USE IN AUTOMOTIVE APPLICATIONS OR OTHER SIMILAR MEDICAL AND AUTOMOTIVE STANDARDS. VICOR DISCLAIMS ANY AND ALL LIABILITY FOR INCLUSION AND/OR USE OF VICOR PRODUCTS IN SUCH EQUIPMENT OR APPLICATIONS AND THEREFORE SUCH INCLUSION AND/OR USE IS AT YOUR OWN RISK.

Terms of Sale

The purchase and sale of Vicor products is subject to the Vicor Corporation Terms and Conditions of Sale which are available at: (<https://www.vicorpower.com/termsconditionswarranty>)

Export Control

This document as well as the item(s) described herein may be subject to export control regulations. Export may require a prior authorization from U.S. export authorities.

Contact Us: <https://www.vicorpower.com/contact-us>

Vicor Corporation
25 Frontage Road
Andover, MA, USA 01810
Tel: 800-735-6200
Fax: 978-475-6715
www.vicorpower.com

email

Customer Service: custserv@vicorpower.com
Technical Support: apps@vicorpower.com